

Duplex Bag Filters And Basket Strainers

Trouble free, continuous operation

Duplex filters permit continuous operation, reducing overall operating costs. Flow can be switched back and forth between two filter vessels or housings, allowing one side to be serviced while the other is in use.

The Rosedale duplex, using a single multi-ported valve operating system (patent applied for), is a better solution, and offers many benefits:

- Four separate valves are used all operated simultaneously by a single lever.
- Valves use the standard butterfly design, known for their effective seal, low pressure drop, and low cost.
- Any of the valves can be serviced individually, without need to disturb the other valves or piping. Replacements are readily available.
- Valves are soft-seated to provide bubble-tight closure.
- A variety of valve seal materials is available for use with a number of hard-to-handle fluids.
- Pressure drop is minimized because the flow path has the equivalent of only four elbows instead of the usual six.
- Mechanical stops assure that the valves are completely open or closed.
- A single-valve pressure balancing vent system is furnished to ease movement of the lever and to fill the just serviced vessel before use.
- Vents in filter covers and drain ports in filter housing speed evacuation and filling.
- Remotely operated power actuators and automatic power actuation (triggered by pressure differential sensing) are offered. Air or electric actuation is best if such power is available.



Construction Materials

Available in carbon steel, 304 stainless steel, or 316 stainless steel.

Internal valve parts other than seals are 316 stainless steel.

Four different materials can be ordered for all seals involved.

All baskets and mesh linings are made of stainless steel. 304 stainless will be supplied with carbon and 304 housings, 316 stainless with 316 housings.

Choosing a Basket Strainer or Bag Filter

Choose between straining a fluid (removing particles down to 74 micron size) and filtering it (removing particles down to 1 micron).

Pressure Drop Data

Basket strainers and bag filters are usually selected so that the pressure drop does not exceed 2 psi, when they are clean. Higher pressure drops may be tolerated, when contaminant loading is low.

The pressure drop data are accurate for all housings with strainer or filter bag baskets. When filter bags are added, total pressure drop becomes the sum of the pressure drop as determined by the steps below plus the pressure drop through the bag as defined on pages 61 and 62.

Follow these easy steps:

1. Using the desired pipe size and approximate flow rate, determine the basic pressure drop from the appropriate graph.
2. Multiply the pressure drop obtained in step 1 by the viscosity correction factor found in the accompanying table. This is the adjusted (clean) pressure drop for all baskets without filter bags.

Note: Filter bags are specified separately. See page 120-130.



	Viscosity, cps								
	1 (H ₂ O)	50	100	200	400	600	800	1000	2000
All unlined baskets	.65	.85	1.00	1.10	1.20	1.40	1.50	1.60	1.80
40-mesh lined	.73	.95	1.20	1.40	1.50	1.80	1.90	2.00	2.30
60-mesh lined	.77	1.00	1.30	1.60	1.70	2.10	2.20	2.30	2.80
80-mesh lined	.93	1.20	1.50	1.90	2.10	2.40	2.60	2.80	3.50
100-mesh lined	1.00	1.30	1.60	2.20	2.40	2.70	3.00	3.30	4.40
200-mesh lined	1.30	1.70	2.10	3.00	3.40	3.80	4.40	5.00	6.80

Selecting A Size

These descriptions and flow charts can aid in size selection. Capacities given are for each of the two vessels in any duplex system.

Model 4-For flow rates to 50 gpm*

- Pipe sizes 1, 2, or 3 inch, flanged
- Basket depth: 12 inches (nominal)

Basket Data

Depth (nominal, inches)	Diameter (inches)	Surface Area	Volume (cu. in.)
12	3.9	1.0	130

Model 6-For flow rates to 100 gpm*

- Delivers 3.4 square feet of basket or bag surface without need for ASME code construction.
- Can be fitted to hold cartridge filter elements
- Pipe sizes 1, 2, 3, or 4 inches (flanged).
- Two basket depths: 18, or 30 inches (nominal)

Basket Data

Depth (nominal, inches)	Diameter (inches)	Surface Area	Volume (cu. in.)
18	5	2.0	350
30	5	3.4	630

Model 8-For flow rates to 220 gpm*

- Can be fitted to hold cartridge filter elements
- Pipe sizes 2, 3, or 4 inch, flanged.
- Two basket depths: 15 or 30 inches (nominal)

Basket Data

Depth (nominal, inches)	Diameter (inches)	Surface Area	Volume (cu. in.)
15	6.7	2.3	500
30	6.7	4.4	1000

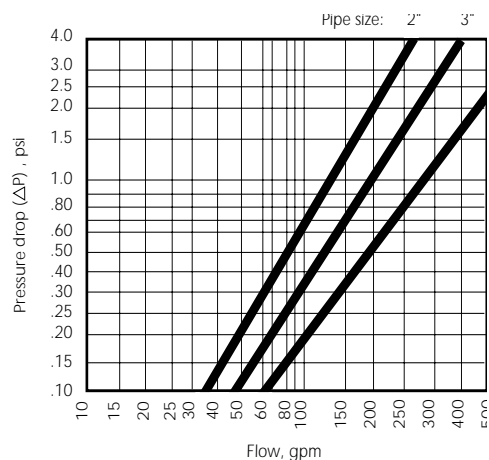
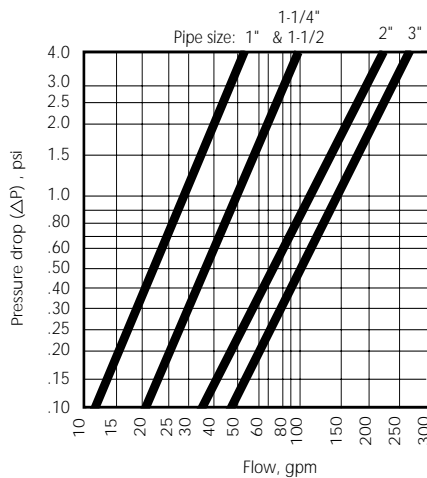
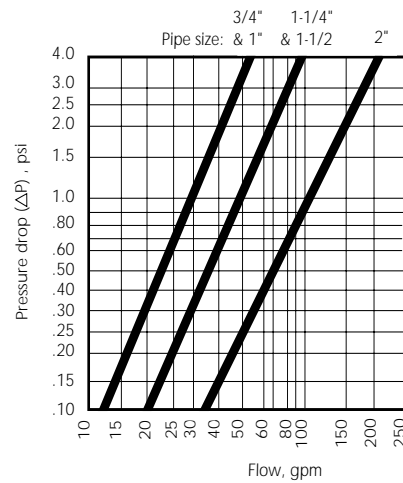

*Based on housing only. Fluid viscosity, filter cartridge used, and expected dirt loading should be considered when sizing a filter.

Single-Basket Models (IN)

Model	Flange Size	A For basket depths				B	B1 (Model 82 only)	C	D	F	G	H	I	J (Model 82 only)
		12	15	18	30									
4	1	18				29.5		9	15	14	19	22.25	7.0	
	2	18				29.5		9	15	14	19	22.25	7.0	
	3	22.125				31.75		11	17	14	19	24.25	7.0	
6	1			25.75	37.75	34.75		9	15	18	20.5	24.25	10.0	
	2			25.75	37.75	34.75		9	15	18	20.5	24.25	10.0	
	3			27.75	39.625	37		11	17	18	20.5	26.25	10.0	
	4			27.625	39.625	41.5		13	18	18	20.5	31	10.0	
8	1		23.75		38.75	44.75	45.75	9	15	22	21.3	32.25	11.6	28.6
	2		23.75		38.75	44.75	45.75	9	15	22	21.3	32.25	11.6	28.6
	3		25.625		40.625	47	48	11	17	22	21.3	34.5	11.6	30.6
	4		25.625		40.625	49.5	50.5	13	18	22	21.3	37	11.6	30.6

The inlets and outlets on all duplex systems come standard in a horizontal configuration (facing opposite directions). The option of arranging the inlet and outlet is available in three positions, 90° apart. The system is designed with flanged tees, allowing the orientation to be changed in the field.

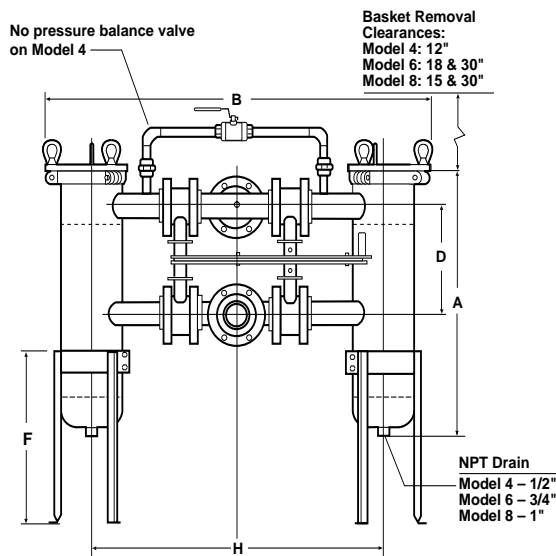
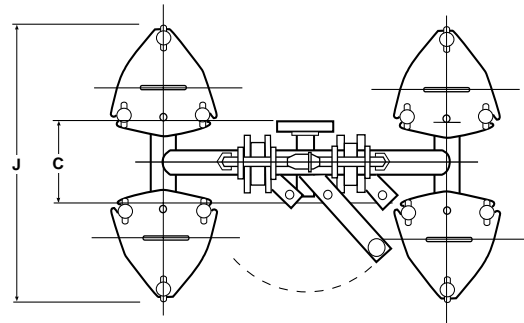
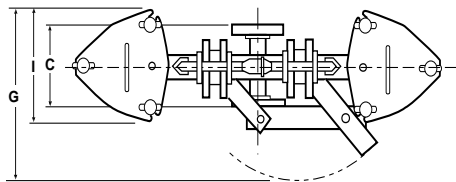

Duplex Models 4, 6, and 8

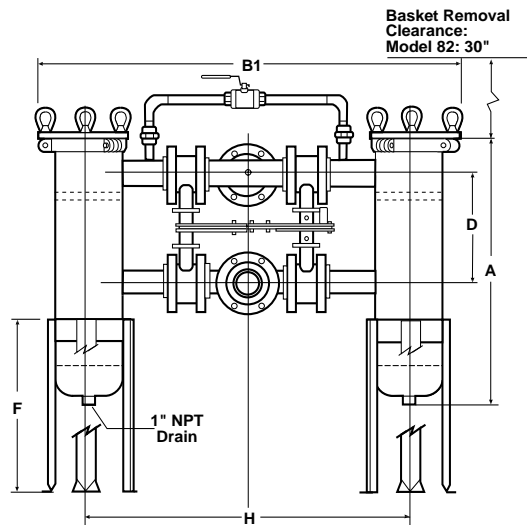

Duplex Model 82