

Information Sheet

Four Function Valve (4-FV)

Features

1. Positive Anti-Syphon
2. Back Pressure
3. Priming Aid - Line Pressure Release
4. Pressure Relief

*A positive diaphragm-type **ANTI-SYPHON** function makes it possible to meter liquids "down hill"; or into the suction side of a circulating pump.*

*The **BACK PRESSURE** function permits metering into atmosphere discharge (open tank) without overpumping due to discharge velocity.*

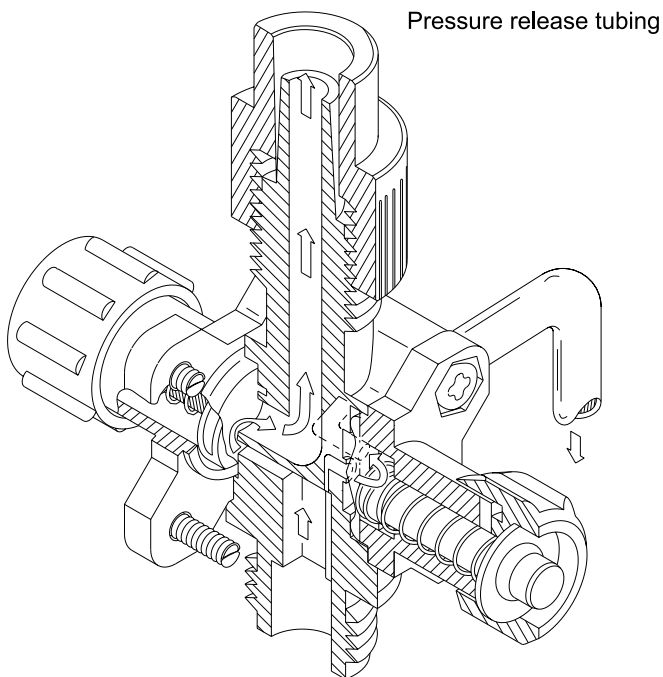
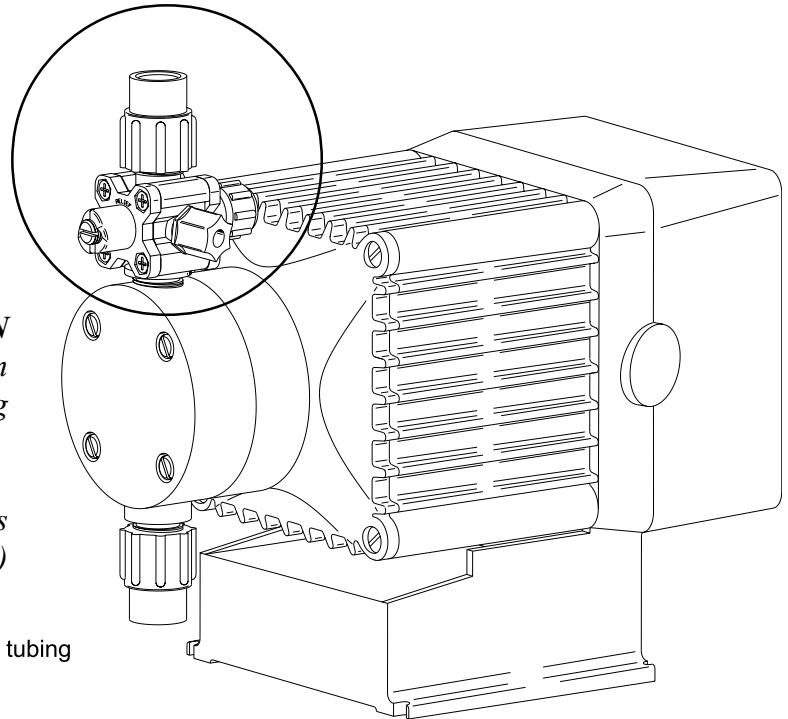

Pressure release tubing

Arrows indicate fluid flow

*The **PRIMING - LINE PRESSURE RELEASE** function makes it easy to de-pressurize the discharge line without loosening tubing or fittings. You can **prime** your LMI pump while it is connected to a pressurized line.*

*The **PRESSURE RELIEF** function is usually not required on electronic pumps, but it is important on any mechanical, motor drive pump.*



8 Post Office Square
Acton, MA 01720 USA
TEL: (978) 263-9800
FAX: (978) 264-9172
<http://www.lmipumps.com>



Instruction Sheet

Four Function Valve (4 FV) Method of Operation

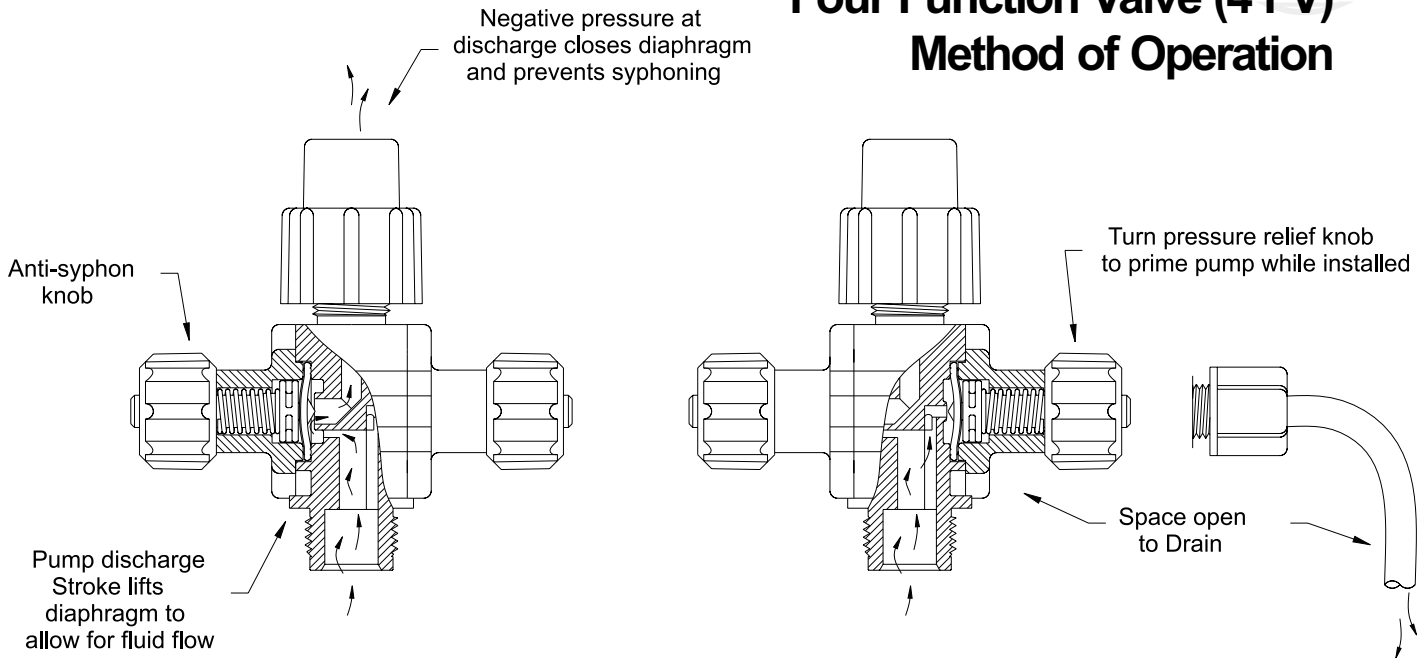

A. PRIMING

1. Connect pressure release tubing to pressure release port.
2. Route tubing to solution reservoir and anchor with a plastic tie.
3. Set pump at 80% speed and 100% stroke. Start pump.
4. Pull or 1/4 turn Pressure Release knob (black knob), holding knob out until solution is visible through translucent pressure release tubing.
5. Pump is now primed.

Note:

- (a) Pump is normally self-priming if suction lift is no more than 5 ft (1.5 m), valves in the pump are wet with water and the above steps (**A1 thru A5**) are followed.
- (b) If the pump does not self prime, remove Four Function Valve Assembly and discharge valve ball, and pour water or solution slowly into discharge port until head is filled. Replace Four Function Valve Assembly and follow steps **A1 through A5** thereafter.

B. DEPRESSURIZING DISCHARGE LINE

1. It is possible to depressurize discharge line and pump head without removal of tubing or loosening of fittings.
Be sure injection check valve is properly installed and is operating. If a gate valve or globe has been installed downstream of injection check valve, it should be closed. Be certain relief tubing is connected and run to chemical solution tank.
2. Pull or 1/4 turn both anti-syphon and pressure release knobs.
3. The discharge line is now depressurized.
4. If injection check valve is of higher elevation than pump head, disconnecting tubing at injection check valve end will allow air to enter and permit solution to drain back to tank.

Part No.	Description	For Liquid Ends	Part No.	Description	For Liquid Ends
28010	0.250" O.D. tubing, PP, PTFE	150 & 190 Series 31693	31686	0.375" O.D. tubing, PVDF, PTFE	192 Series
31693	0.250" O.D. tubing, PP, PTFE	150 & 190 Series	25900	0.5" O.D. tubing, PP, PTFE	75 & 85 Series
30625	0.250" O.D. tubing, PVC, Macroflex™	150 & 190 Series	33060	0.5" O.D. tubing, PVC, Macroflex™	71, 81 & 178 Series
30475	0.250" O.D. tubing, PVDF, Hypalon®	150 Series	25700	0.5" O.D. tubing, PVC, PTFE	70 & 80 Series
28046	0.250" O.D. tubing, PVDF, PTFE	150 & 190 Series	30419	0.5" O.D. tubing, PVDF, Hypalon®	71 & 81 Series
31694	0.250" O.D. tubing, PVDF, PTFE	150 & 190 Series	32030	0.5" O.D. tubing, PVDF, Macroflex™	112 Series
28022	0.375" O.D. tubing, PP, PTFE	95 & 190 Series	34626	0.5" O.D. tubing, PVDF, Fluorofilm™	26, 30 & 36 Series
30600	0.375" O.D. tubing, PP, PTFE	191 Series	27043	0.5" O.D. tubing, PVDF, PTFE	70 & 80 Series
31682	0.375" O.D. tubing, PVC, Macroflex™	91 & 191 Series	34627	1/2" NPT, PVDF, Fluorofilm™	20 & 30 Series
33050	0.375" O.D. tubing, PVC, Macroflex™	61, 91, 168 & 198 Series	26615	1/4" NPT, PP, PTFE	70, 80 & 90 Series
25690	0.375" O.D. tubing, PVC, PP, PTFE	90 Series	26035	1/4" NPT, PVC, PTFE	70, 80 & 90 Series
30420	0.375" O.D. tubing, PVDF, Hypalon®	90 Series	27051	1/4" NPT, PVDF, PTFE	70, 80 & 90 Series
27048	0.375" O.D. tubing, PVDF, PTFE	90 Series			